

# MATERIAL HANDLING

## Hand Winch Automatic Brake

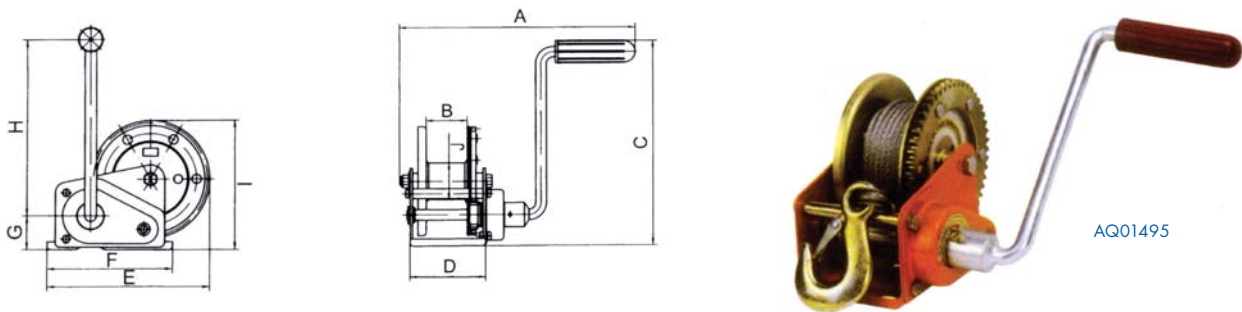

Code	Mod	Capacity		Gear Ratio	Dimension										Handle force N	Net weight kg
		kg	lb		A	B	C	D	E	F	G	H	I	J		
AQ01495	KWB 100	454	1000	3:5:1	288.5	50	252	92	179.5	140	38	200	143.5	45	160	3.1
AQ01496	KWB 120	545	1200	4:25:1	288.5	50	252	92	181.5	140	38	200	146	45	160	3.3
AQ01497	KWB 140	635	1400	5:3:1	288.5	50	252	92	184	140	38	200	148	45	160	3.7

## Hand Winch Manual Brake



Code	Mod	Capacity		Gear Ratio	Dimension								N.W kg	No. of Speed
		kg	lb		A	B	C	D	E	F	G	H		
AQ01490	KWA 100	454	1000	2:9:1	232	51	180	88	184	156	25	90	2.8	Single
AQ01491	KWA 120	545	1200	3:7:1	232	51	180	88	184	156	25	90	2.8	Single
AQ01492	KWA 140	635	1400	4:2:1	232	51	180	88	184	156	25	90	2.8	Single
AQ01493	KWA 200	908	2000	10.35:1/4.6:1	310	65	250	130	243	178	25	90	6.2	Double
AQ01494	KWA 400	1135	2500	11.5:1/5.1:1	310	65	250	130	257	190	25	90	6.5	Double

## Wire Rope Clip (GALV'D)

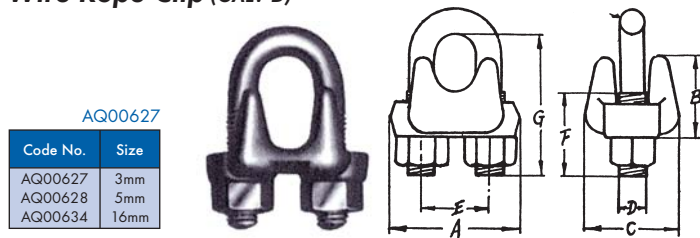

Code No.	Size	A	B	C	D	E	F	G	100WT/PCS kg
AQ00627	3mm								
AQ00628	5mm								
AQ00634	16mm								
AQ00629	6	22.5	14	17	5	12	14	24.8	2.1
AQ00630	8	28	17	21	6	15	16	30.66	3.7
AQ00631	9	38	21	28	8	19	20	37.95	8.5
AQ00632	12	45	27	34	10	24	25	47.55	16
AQ00633	14	52	32	40	12	29	30	57.15	25
AQ00635	19	62	38	46.5	14	36	36	71.73	43
AQ00636	22	69	43	51.5	16	40	39	78.73	60
AQ00637	25	76	50	56	18	43	44	90.4	82
AQ01052	28	85	57	62	20	48	48	96.9	112
AQ01053	32	93	61	67	22	55	51	110.4	150
AQ01054	40	111	73	81	24	64	62	122.5	254
AQ01055	45	123	86	88	27	72	70	139.5	343
AQ01056	50	135	95	95	30	80	88	156	456

## Wire Rope Clip (MALLEABLE)

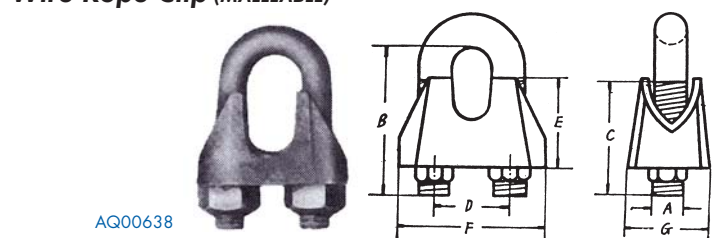

Code No.	Size	A	B	C	D	E	F	G	100WT/PCS kg
AQ00638	1/8	3	20	12	9	9.5	19	12	1.3
AQ00639	3/16	5	26.3	14	11	10.8	22	13.5	16
AQ00640	1/4	6	26	14	12.5	11.5	25	15.5	2.4
AQ00641	5/16	8	31	16	15.5	16	31	18	3.7
AQ00642	3/8	9	37.5	20	21	20	40	22	8.1
AQ00643	1/2	12	46.4	24	25	26	47	25	14.6
AQ00644	5/8	16	57.1	28	30	31	55	28	23.2
AQ00645	11/16	17	64.25	40	33	35	58.5	28.5	0.3
AQ00646	3/4	19	71	34	36.5	36	65	31	45
AQ00647	7/8	22	77.4	38	40	43	72	36	58.1
AQ00648	1	25	88.1	44	45	48	80	40	89.2

### Allinton Engineering & Trading Pte Ltd

Head Office: Block 803, King George's Avenue #01-234 Singapore 200803. Tel: 6296 0679 (10 lines) 6292 7728 Fax: 6297 0024

Branch Office: 21 Tuas Basin Link Singapore 638782 Tel: 6265 1888 (10 lines) Fax: 6265 5623

Web-site: <http://www.allinton.com.sg> E-mail: [allinton@singnet.com.sg](mailto:allinton@singnet.com.sg)

# MATERIAL HANDLING

## Crane Scale LCD Display – Model KCS



- A compact measuring device for weighing loads lifting.
- Appropriate tackle can be attached to assist in the lifting and weighing.
- The crane weighers have liquid crystal display (LCD), which can tare as well as show either the gross or net loads.
- It also indicates the load protection at 110% of the gross weight and the status of the battery.
- Conforms to CE safety standard.

Code No.	Model	Measuring Range (t)	Indexing Accuracy (kg)	Resolution Step (kg)	Dimensions			N.W. kg	Packing Size mm
					A (mm)	B (mm)	C (mm)		
AQ01212	KCS05	0-0.5	0.2	4	315	430	540	10	470 x 260 x 410
AQ01213	KCS10	0-1	0.5	10	315	430	540	25	470 x 260 x 410
AQ01214	KCS20	0-2	1	20	315	430	540	25	470 x 260 x 410
AQ01215	KCS30	0-3	1	20	315	430	540	25	470 x 260 x 410
AQ01216	KCS50	0-5	2	40	315	570	710	30	470 x 260 x 410
AQ01217	KCS100	0-10	5	100	355	650	820	60	780 x 360 x 420
AQ01218	KCS150	0-15	5	100	355	740	930	60	780 x 360 x 420

## GALV'D Wire Rope 6 x 24 (220MTR)

Code No.	Size
AQ00615	2mm
AQ00616	3mm
AQ00617	5mm
AQ00618	6mm
AQ00619	8mm
AQ00620	9mm
AQ00621	10mm
AQ00622	12mm
AQ00623	16mm
AQ00624	19mm
AQ00625	22mm
AQ00626	25mm

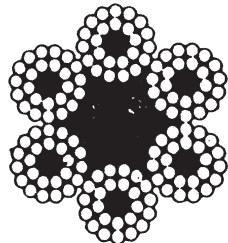

AQ00615



16111

Stainless Steel Snap Hook, SS 316.

Code No.	Size		O.L		M.B.L		N.W	
	mm	inch	mm	inch	TON	LBS	kg	
S-2450-050	5	3/16	50	2.0	0.20	440	0.02	
S-2450-060	6	1/4	60	2.4	0.24	500	0.03	
S-2450-070	7	9/32	70	2.8	0.36	800	0.05	
S-2450-080	8	5/16	80	3.1	0.46	1000	0.07	
S-2450-090	9	3/8	90	3.5	0.50	1100	0.09	
S-2450-100	10	13/32	100	4.2	0.70	1500	0.14	
S-2450-120	11	7/16	120	4.7	0.90	2000	0.19	



16112

Stainless Steel Fast Swivel Snap, SS 316.

Code No.	Size		O.L		M.B.L		N.W	
	mm	inch	mm	inch	TON	LBS	kg	
S-251-1	16	5/8	86	3.4	0.15	330	0.06	
S-251-2	19	3/4	100	4.0	0.20	440	0.10	
S-251-3	22	7/8	120	4.7	0.30	660	0.16	



16113

Stainless Steel Eye Hook, SS 316.

Code No.	Size		O.L		M.B.L		N.W	
	mm	inch	mm	inch	TON	LBS	kg	
S-251-19	19	3/4	105	4.1	0.9	2000	0.15	
S-251-28	28	1-1/8	120	4.7	1.2	2600	0.20	